



US009312316B2

(12) **United States Patent**
You et al.

(10) **Patent No.:** **US 9,312,316 B2**
(45) **Date of Patent:** ***Apr. 12, 2016**

(54) **ORGANIC LIGHT EMITTING DIODE DISPLAY AND MANUFACTURING METHOD OF THE SAME**

(58) **Field of Classification Search**
CPC H01L 51/5246; H01L 27/32
See application file for complete search history.

(71) Applicant: **SAMSUNG DISPLAY CO., LTD.**,
Yongin, Gyeonggi-Do (KR)

(56) **References Cited**

(72) Inventors: **Chun-Gi You**, Yongin (KR); **Joon-Hoo Choi**, Yongin (KR)

U.S. PATENT DOCUMENTS

(73) Assignee: **Samsung Display Co., Ltd.**, Yongin-si (KR)

7,652,305 B2	1/2010	Chatterjee et al.	
8,748,897 B2*	6/2014	Choi et al.	257/59
8,907,331 B2*	12/2014	Jinta et al.	257/40
8,981,359 B2*	3/2015	Kum et al.	257/40
9,029,847 B2*	5/2015	Lee et al.	257/40

(*) Notice: Subject to any disclaimer, the term of this patent is extended or adjusted under 35 U.S.C. 154(b) by 48 days.

(Continued)

This patent is subject to a terminal disclaimer.

FOREIGN PATENT DOCUMENTS

CN	1509125 A	6/2004
EP	1 868 246	12/2007

(Continued)

(21) Appl. No.: **14/165,331**

(22) Filed: **Jan. 27, 2014**

Primary Examiner — Evan Pert

(65) **Prior Publication Data**

US 2014/0138668 A1 May 22, 2014

(74) *Attorney, Agent, or Firm* — Lewis Roca Rothgerber Christie LLP

Related U.S. Application Data

(63) Continuation of application No. 13/206,423, filed on Aug. 9, 2011, now Pat. No. 8,637,333.

(57) **ABSTRACT**

An organic light emitting diode (OLED) display includes: a first substrate including a display area and a non-display area; a driving element on the display area of the first substrate, and including a driving thin film transistor, a switching thin film transistor, and a capacitor; a circuit unit on the non-display area of the first substrate; an organic light emitting element on the driving element, and including a pixel electrode, an organic emission layer, and a common electrode; an inorganic protective layer covering the circuit unit and the common electrode of the organic light emitting diode; a sealing member on the inorganic protective layer in the non-display area of the first substrate; and a second substrate on the sealing member.

(30) **Foreign Application Priority Data**

Dec. 30, 2010 (KR) 10-2010-0139428

(51) **Int. Cl.**

H01L 51/52	(2006.01)
H01L 51/54	(2006.01)
H01L 27/32	(2006.01)
H01L 51/56	(2006.01)

(52) **U.S. Cl.**

CPC **H01L 27/3244** (2013.01); **H01L 51/5246** (2013.01); **H01L 51/5253** (2013.01); **H01L 51/5259** (2013.01); **H01L 51/56** (2013.01)

24 Claims, 10 Drawing Sheets

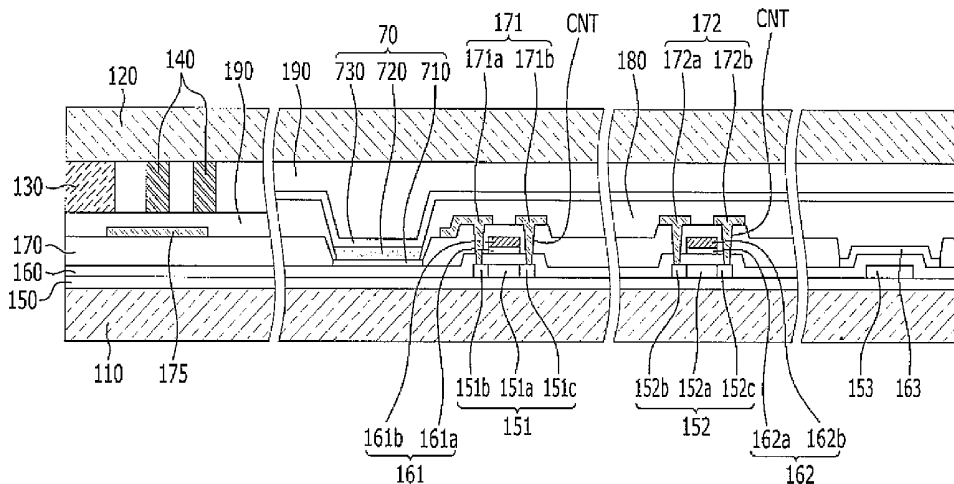

(56)

References Cited

2012/0181526 A1 7/2012 Kasahara et al.

U.S. PATENT DOCUMENTS

FOREIGN PATENT DOCUMENTS

2004/0206953 A1 10/2004 Morena et al.
2006/0163565 A1 7/2006 Park et al.
2008/0303424 A1 12/2008 Mitsuya et al.
2010/0181557 A1 7/2010 Sun
2010/0244005 A1 9/2010 Gyoda
2011/0114991 A1 5/2011 Lee

KR 10-0703518 B1 3/2007
KR 10-0838082 B1 6/2008
KR 10-0908727 B1 7/2009

* cited by examiner

FIG. 1

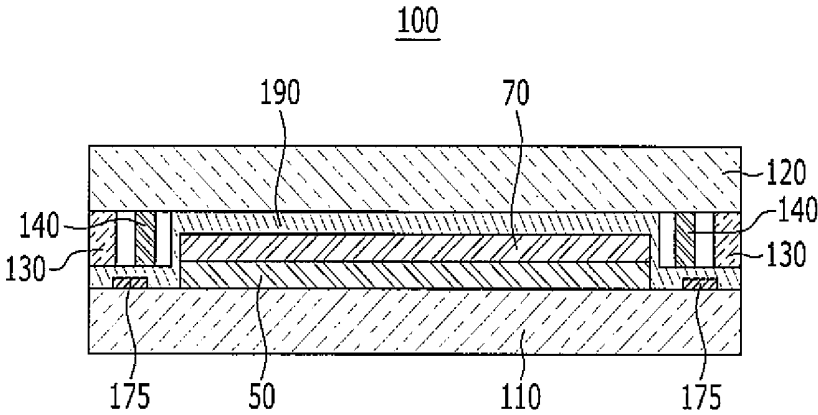

FIG. 2

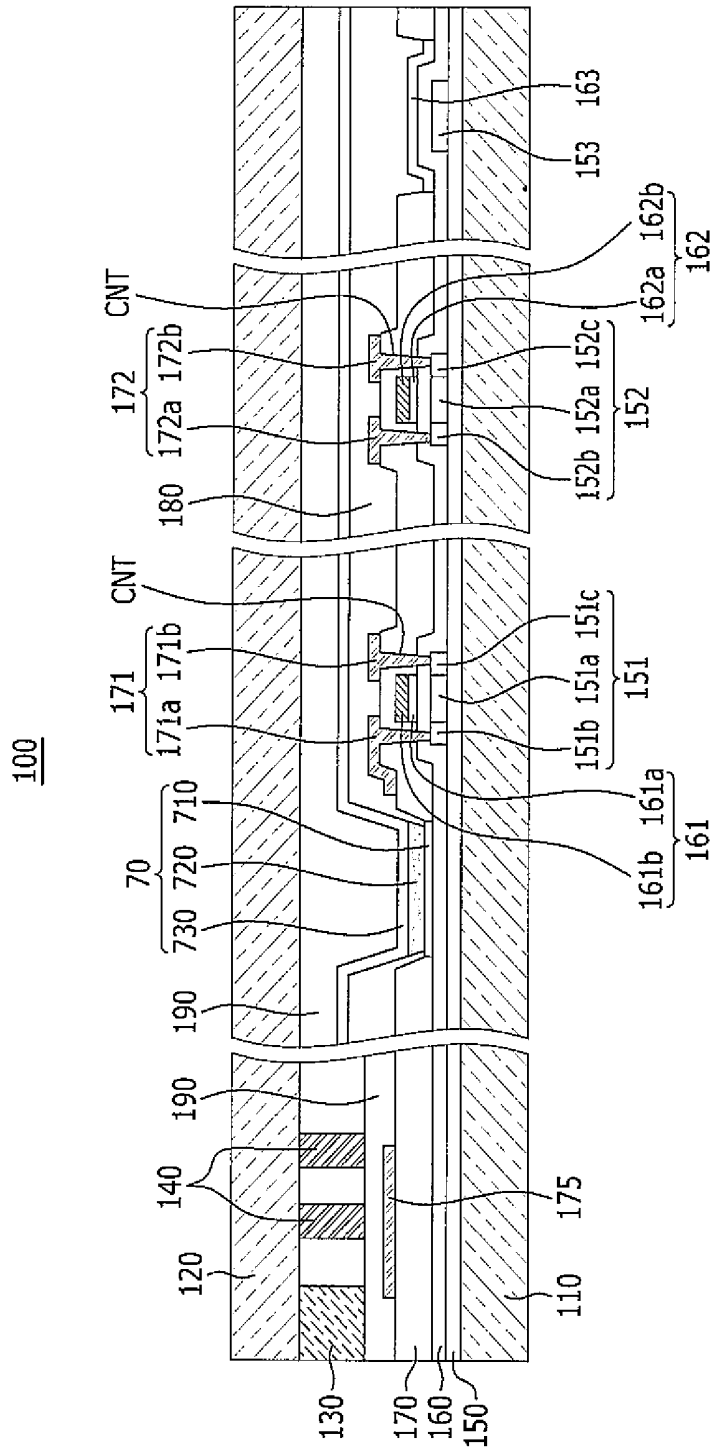

FIG. 3A

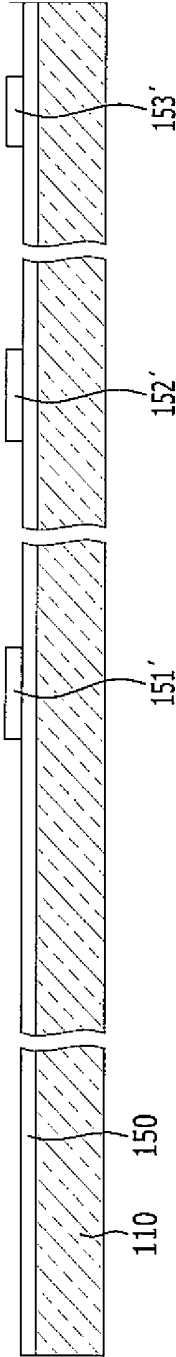

FIG. 3B

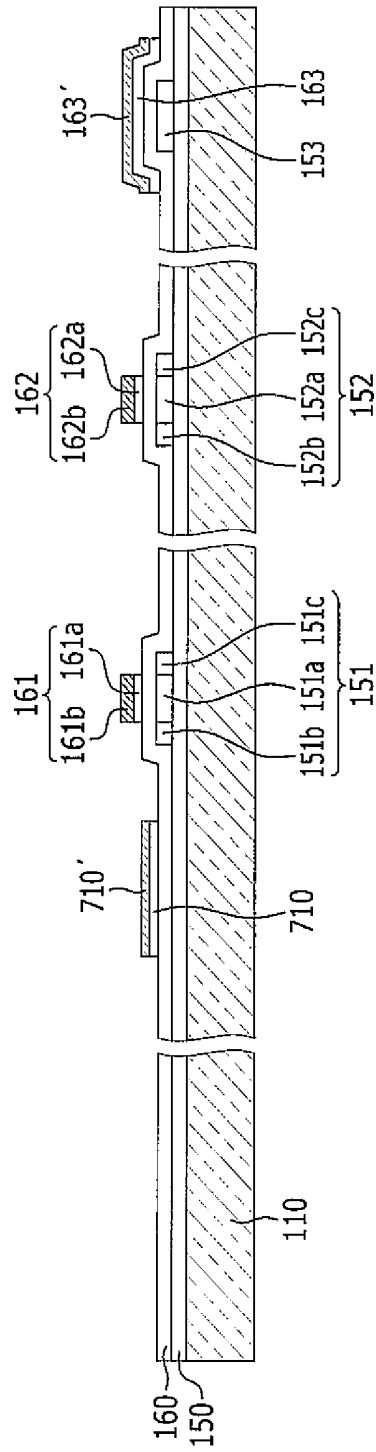

FIG. 3C

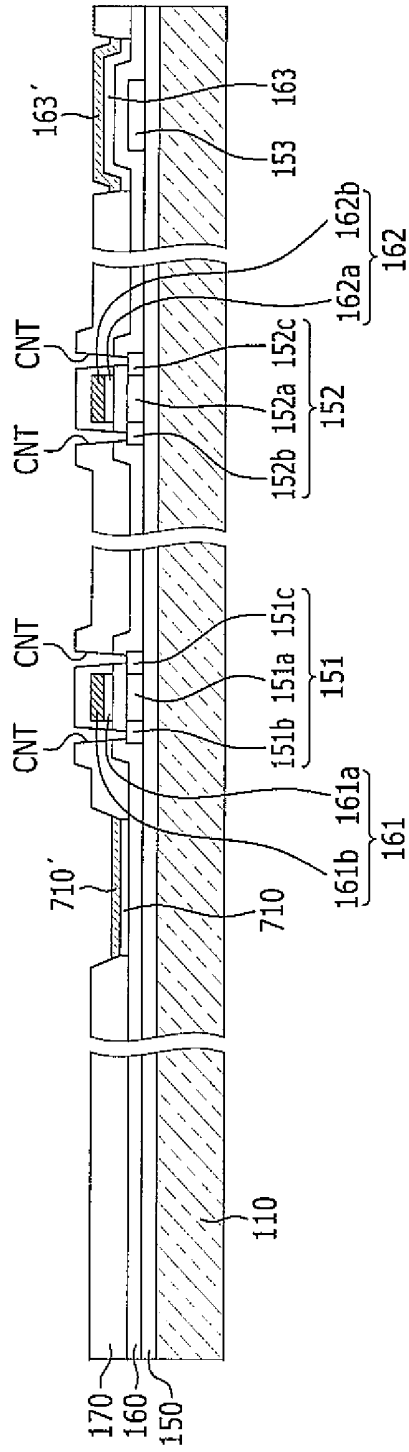

FIG. 3D

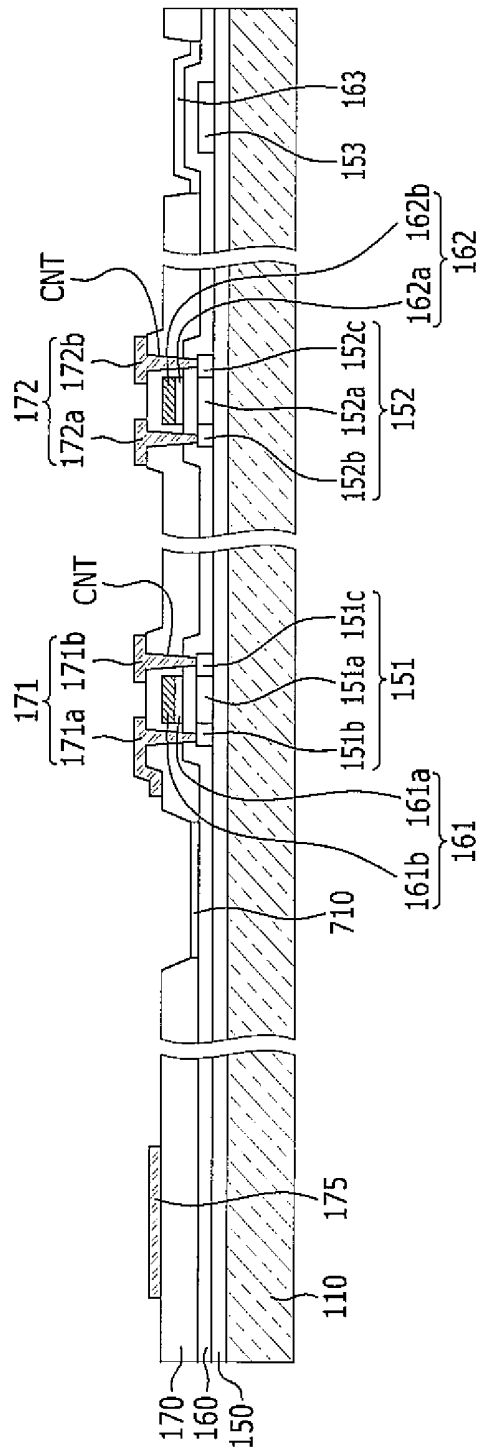

FIG. 3F

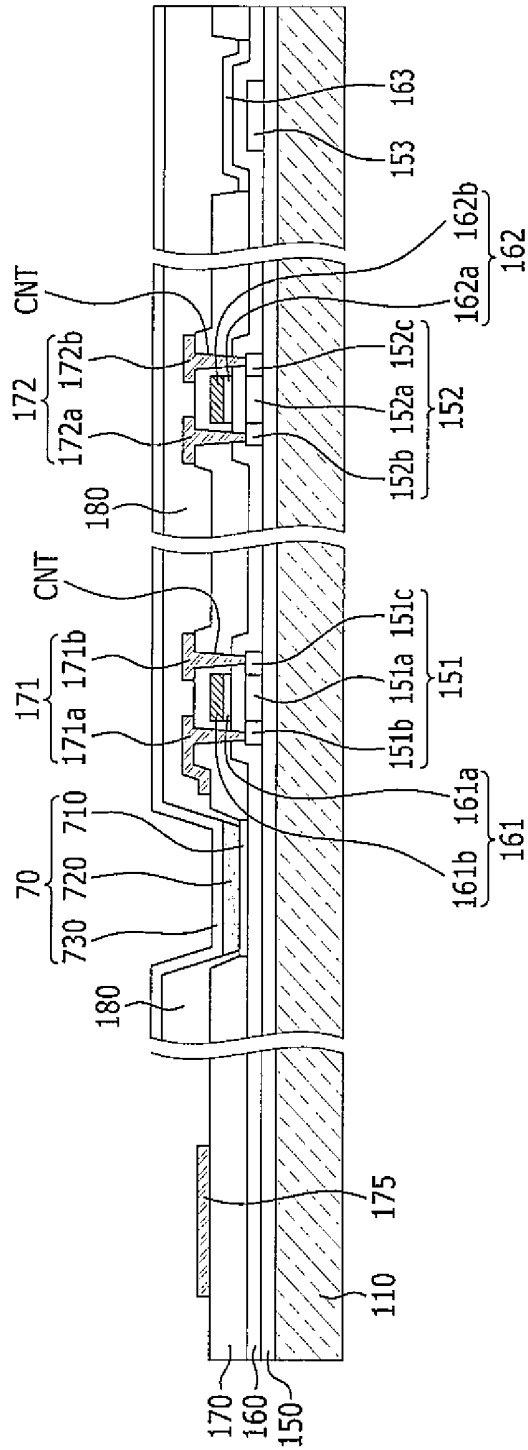

FIG. 3G

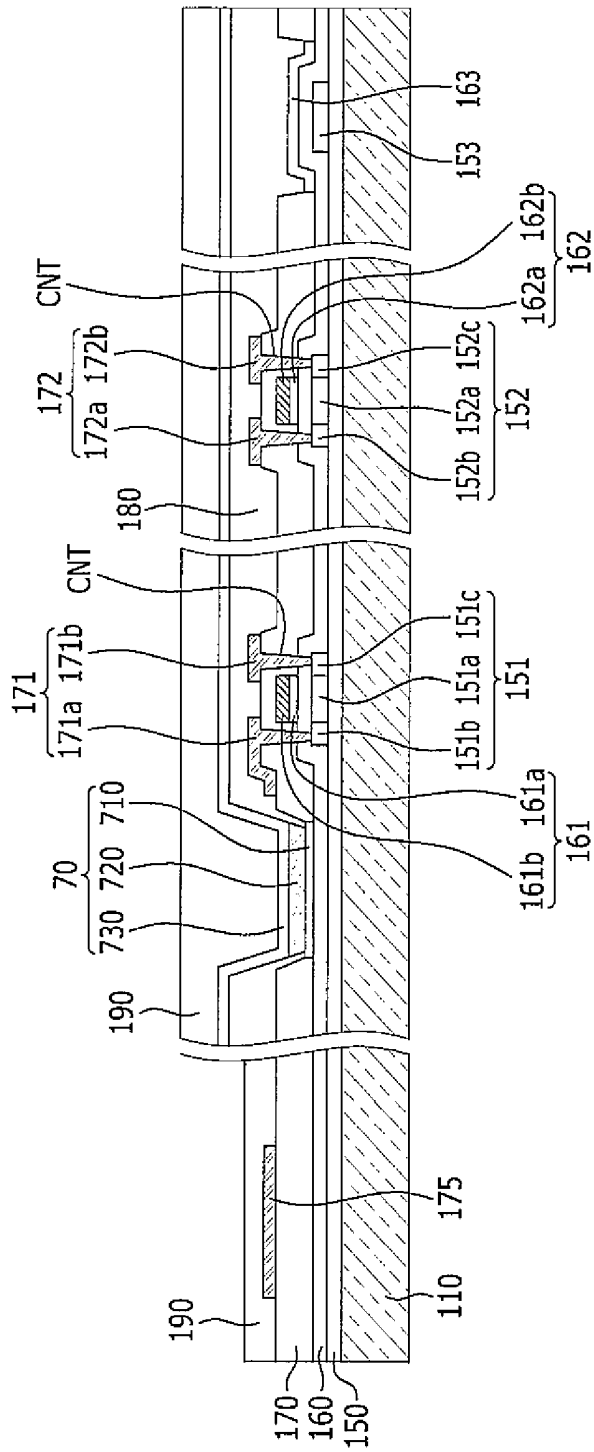
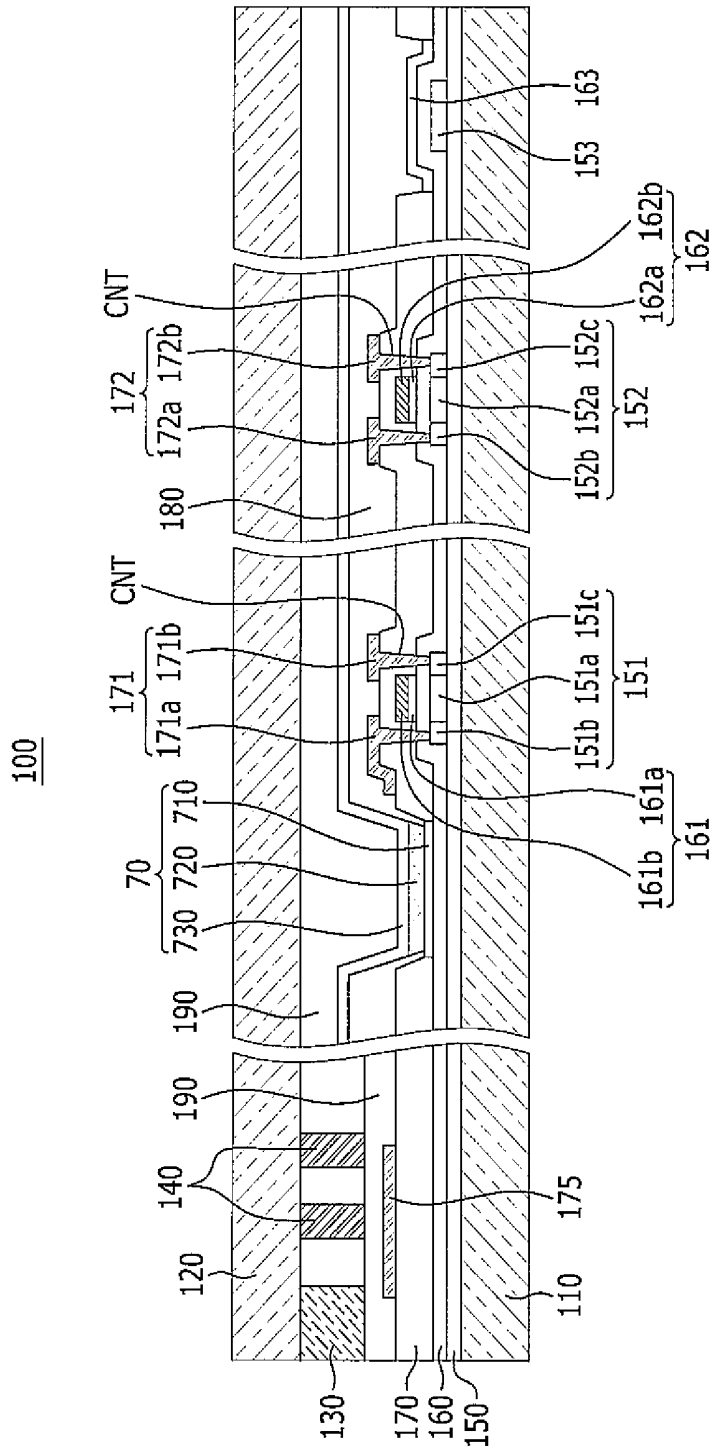

FIG. 3H



**ORGANIC LIGHT EMITTING DIODE
DISPLAY AND MANUFACTURING METHOD
OF THE SAME**

CROSS-REFERENCE TO RELATED
APPLICATIONS

This application is a continuation of U.S. patent application Ser. No. 13/206,423, filed Aug. 9, 2011, which claims priority to and the benefit of Korean Patent Application No. 10-2010-0139428, filed Dec. 30, 2010, the entire content of both of which is incorporated herein by reference.

BACKGROUND

1. Field

The described technology relates generally to an organic light emitting diode (OLED) display and a manufacturing method thereof.

2. Description of Related Art

An organic light emitting diode (OLED) display is a flat panel display which can be made lightweight and thin because it has a self-luminous characteristic and requires no separate light source. Particularly, the OLED display exhibits quality characteristics such as low power consumption, high luminance, high response speed, and as such, the OLED display receives much attention as a next-generation display device.

In general, an OLED display includes an organic light emitting element and a thin film transistor for driving the same. A pixel defining layer (PDL) defining a pixel area is formed on the thin film transistor, and the organic light emitting element is formed in the pixel area. The organic light emitting element includes an anode, a cathode, and an organic emission layer. Holes and electrons are injected from the anode and the cathode, respectively, to form excitons, and the excitons make a transition to a ground state, thereby causing the organic light emitting diode to emit light.

The organic light emitting element formed with an organic material may deteriorate in performance when combined with moisture or oxygen, and therefore an encapsulation technique is used in the OLED display to prevent moisture and oxygen from penetrating the display. In general, an encapsulation substrate formed with glass or a metal may be used to encapsulate a display substrate where the organic light emitting element is formed, and the encapsulation substrate may be adhered to the display substrate using a sealant.

The sealant is applied (or coated) between the display substrate and the encapsulation substrate, and hardened by an ultraviolet (UV) laser irradiated thereto. A circuit unit or a wire unit that electrically connects the organic light emitting element with external devices is formed on the display substrate of the OLED display, and when the sealant is applied to (or coated on) the circuit unit or the wire unit, the circuit unit or the wire unit may be damaged during a sealant hardening process.

Thus, the sealant may be applied (or coated) so as to avoid the circuit unit or the wire unit, such that a dead space is increased at the outer side of the display substrate. Particularly, when the OLED display is increased in size, a getter may be additionally formed in addition to the sealing member, and the getter causes the dead space to be further increased.

The above information disclosed in this Background section is only for enhancement of understanding of the background of the described technology and therefore it may

contain information that does not form the prior art that is already known in this country to a person of ordinary skill in the art.

SUMMARY

Aspects of embodiments of the present invention are directed toward an organic light emitting diode (OLED) display for reducing a dead space, and a manufacturing method thereof.

Further, aspects of embodiments of the present invention are directed toward an OLED display that can protect an organic light emitting element formed in a display area of a display substrate and a circuit unit formed in a non-display area of the display substrate, and can improve adhesiveness between the display substrate and an encapsulation substrate, and a manufacturing method thereof.

An organic light emitting diode (OLED) display according to an exemplary embodiment includes: a first substrate including a display area and a non-display area; a driving element on the display area of the first substrate, and including a driving thin film transistor, a switching thin film transistor, and a capacitor; a circuit unit on the non-display area of the first substrate; an organic light emitting element on the driving element, and including a pixel electrode, an organic emission layer, and a common electrode; an inorganic protective layer covering the circuit unit and the common electrode of the organic light emitting diode; a sealing member on the inorganic protective layer in the non-display area of the first substrate; and a second substrate on the sealing member.

The OLED display may further include a getter on the inorganic protective layer in the non-display area of the first substrate, the getter being closer to the display area than the sealing member is.

The sealing member may be at a location at least partially overlapping the circuit unit.

The OLED display may further include a getter on the inorganic protective layer in the non-display area of the first substrate, the getter being closer to the display area than the sealing member is.

The inorganic protective layer may include silicon nitride (SiNx) or silicon oxide (SiOx).

The OLED display may further include a getter on the inorganic protective layer in the non-display area of the first substrate, the getter being closer to the display area than the sealing member is.

The sealing member may include epoxy or frit.

The OLED display may further include a getter on the inorganic protective layer in the non-display area of the first substrate, the getter being closer to the display area than the sealing member is.

The first substrate and the second substrate may be formed of glass.

The OLED display may further include a getter on the inorganic protective layer in the non-display area of the first substrate, the getter being closer to the display area than the sealing member is.

A method for manufacturing an organic light emitting diode (OLED) display according to another exemplary embodiment includes: forming a driving element and a circuit unit in a display area and a non-display area of a first substrate, respectively, the driving element including a thin film transistor, a switching transistor, and a capacitor; forming an organic light emitting element, including a pixel electrode, an organic emission layer, and a common electrode, on the driving element; forming an inorganic protective layer to cover the circuit unit and the common electrode of the organic light

emitting element; applying a sealant to the inorganic protective layer in the non-display area of the first substrate; disposing a second substrate on the sealant; and adhering the first substrate and the second substrate to each other by hardening the sealant.

The method for manufacturing may further include forming a getter on the inorganic protective layer at a location in the non-display area of the first substrate, the getter being closer to the display area than the sealant is.

The sealant may be applied to a location at least partially overlapping the circuit unit.

The method for manufacturing may further include forming a getter on the inorganic protective layer at a location in the non-display area of the first substrate, the getter being closer to the display area than the sealant is.

The inorganic protective layer may include silicon nitride (SiN_x) or silicon oxide (SiO_x).

The method for manufacturing may further include forming a getter on the inorganic protective layer at a location in the non-display area of the first substrate, the getter being closer to the display area than the sealant is.

The sealant may include epoxy or frit.

The method for manufacturing may further include forming a getter on the inorganic protective layer at a location in the non-display area of the first substrate, the getter being closer to the display area than the sealant is.

The first substrate and the second substrate may be formed of glass.

The method for manufacturing may further include forming a getter on the inorganic protective layer at a location in the non-display area of the first substrate, the getter being closer to the display area than the sealant is.

The sealant may be hardened by irradiating ultraviolet (UV) light thereto.

The method for manufacturing may further include forming a getter on the inorganic protective layer at a location in the non-display area of the first substrate, the getter being closer to the display area than the sealant is.

According to exemplary embodiments, the sealing member is formed to be at least partially overlapped with the circuit unit at the outer side of the display substrate so that the dead space can be reduced.

Further, the sealant may be coated on the inorganic protective layer so that damage to the organic light emitting element and the circuit unit during a substrate adhering process can be prevented, and adhesiveness of the sealant can be improved.

BRIEF DESCRIPTION OF THE DRAWINGS

FIG. 1 is a schematic cross-sectional view of an organic light emitting diode (OLED) display according to an exemplary embodiment.

FIG. 2 is an enlarged cross-sectional view of an OLED display according to an exemplary embodiment.

FIG. 3A to FIG. 3H sequentially show a manufacturing method of an OLED display according to an exemplary embodiment.

DETAILED DESCRIPTION

The present invention will be described more fully hereinafter with reference to the accompanying drawings, in which exemplary embodiments of the invention are shown.

The drawings and description are to be regarded as illustrative in nature and not restrictive. Like reference numerals designate like elements throughout the specification. In the drawings, for better understanding and ease of description,

thicknesses of some layers and areas are excessively displayed, but the present invention is not limited thereto.

It will be understood that when an element such as a layer, film, region, or substrate is referred to as being "on" another element, it can be directly on the other element or intervening elements may also be present therebetween.

FIG. 1 is a schematic cross-sectional view of an organic light emitting diode (OLED) display according to an exemplary embodiment, and a configuration of an OLED display 100 according to the present exemplary embodiment will be described with reference to FIG. 1.

Referring to FIG. 1, an OLED display 100 according to the present exemplary embodiment includes a first substrate 110, a second substrate 120, and a sealing member 130 disposed between the first substrate 110 and the second substrate 120. In the present exemplary embodiment, the first substrate 110 indicates a display substrate, and the second substrate 120 indicates an encapsulation substrate for sealing the display substrate.

The first substrate 110 includes a display area that substantially displays an image by emitting light, and a non-display area. A driving element 50 and an organic light emitting element 70 are formed on the display area of the first substrate 110. The driving element 50 includes a thin film transistor formed of a plurality of electrodes, and a semiconductor layer and a capacitor, and drives the organic light emitting element 70 using them. The thin film transistor includes a driving thin film transistor and a switching thin film transistor.

A circuit unit 175 is formed on the non-display area of the first substrate 110. In the circuit unit 175, a wire pattern is formed to electrically connect the organic light emitting element 70 with an external device.

The OLED display 100 according to the present exemplary embodiment may further include a getter 140. The getter 140 is formed on the non-display area of the first substrate 110 to extend the life-span and improve the reliability of the organic light emitting element by reducing (or eliminating) moisture or oxygen inside the OLED display 100. The getter 140 is disposed closer to the display area than the sealing member 130.

In the present exemplary embodiment, an inorganic protective layer 190 is formed on the organic light emitting element 70 and the circuit unit 175 respectively formed on the display area and the non-display area of the first substrate 110. Accordingly, in the display area, the inorganic protective layer 190 can protect the organic light emitting element 70 by contacting the second substrate 120. In the non-display area, the inorganic protective layer 190 is disposed between (or at) the circuit unit 175 and a lower portion of the sealing member 130 and the getter 140, to protect the circuit unit 175.

FIG. 2 is an enlarged cross-sectional view of an OLED display according to an exemplary embodiment. In further detail, in FIG. 2, the left side of the drawing is an enlarged view of the non-display area of the OLED display 100, and the rest is an enlarged view of the display area of the OLED display 100 where the driving thin film transistor, the switching thin film transistor, and the capacitor are formed. Hereinafter, the configuration of the OLED display 100 according to the present exemplary embodiment will be described in further detail with reference to FIG. 2.

Referring to FIG. 2, the first substrate 110 and the second substrate 120 are arranged opposite to each other, interposing the sealing member 130 and the getter 140 therebetween. The first substrate 110 and the second substrate 120 may be respectively formed with an insulating material such as glass, quartz, or ceramic.

A buffer layer **150** is formed on the first substrate **110**. In one embodiment, the buffer layer **150** is formed with silicon nitride (SiNx), silicon oxide (SiOx), and/or silicon oxynitride (SiOxNy). Here, the buffer layer **150** may be omitted according to the material and the processing condition of the first substrate **110**.

The driving thin film transistor, the switching thin film transistor, and the capacitor are formed on the buffer layer **150**. The driving thin film transistor includes a driving semiconductor layer **151**, a driving gate electrode **161**, and a driving source/drain electrode **171**, and the switching thin film transistor includes a switching semiconductor layer **152**, a switching gate electrode **162**, and a switching source/drain electrode **172**. Further, the capacitor includes a first capacitor plate **153** and a second capacitor plate **163**. The thin film transistors and the capacitor will be described according to the layering sequence of the respective constituent elements.

The driving semiconductor layer **151**, the switching semiconductor layer **152**, and the first capacitor plate **153** are formed on the buffer layer **150**. In one embodiment, the driving semiconductor layer **151** and switching semiconductor layer **152** are formed with a polycrystalline silicon layer, and respectively include channel areas **151a** and **152a** that are not doped with any impurities, and p+ doped source/drain areas **151b**, **151c**, **152b**, and **152c** respectively formed on opposite sides of the channel regions **151a** and **152a**. Here, the type of the impurity may vary according to the type of the thin film transistor.

A gate insulating layer **160** is formed on the driving semiconductor layer **151**, the switching semiconductor layer **152**, and the first capacitor plate **153**. The gate insulating layer **160** may be formed with silicon nitride or silicon oxide.

The driving gate electrode **161**, the switching gate electrode **162**, and the second capacitor plate **163** are formed on the gate insulating layer **160**, and a pixel electrode **710** is formed in a pixel area. The driving gate electrode **161** and the switching gate electrode **162** respectively include transparent layers **161a** and **162a** and metal layers **161b** and **162b**, and are connected with gate lines formed of a lower gate line and an upper gate line.

The pixel electrode **710**, the transparent layers **161a** and **162a** of the gate electrode and the lower gate line may be formed with a transparent conductive material such as indium tin oxide (ITO) or indium zinc oxide (IZO). In addition, the metal layers **161b** and **162b** and the upper gate line may be formed with a low resistance metal such as aluminum, copper, silver, or molybdenum. The transparent layers **161a** and **162a** suppress lift-off or peeling by enhancing adhesiveness with the gate insulating layer **160**, and the metal layers **161b** and **162b** prevent a signal delay by enhancing conductivity thereof. The metal layers **161b** and **162b** and the upper gate line may have a multi-layered structure.

An interlayer insulating layer **170** is formed on the driving gate electrode **161** and the switching gate electrode **162**. In the interlayer insulating layer **170**, contact holes CNT that expose the source/drain areas **151b**, **151c**, **152b**, and **152c** of each of the driving semiconductor layer **151** and the switching semiconductor layer **152** is formed. In addition, a pixel opening and a capacitor plate opening are formed in the interlayer insulating layer **170** to respectively expose most of the pixel electrode **710** and the second capacitor plate **163**. Like the gate insulating layer **160**, the interlayer insulating layer **170** may include silicon nitride or silicon oxide.

The driving source/drain electrode **171** and the switching source/drain electrode **172** are formed on the interlayer insulating layer **170**. The driving drain electrode, the driving source electrode, the switching drain electrode, and the

switching source electrode **171a**, **171b**, **172a**, and **172b** are respectively connected with the source/drain areas **151b**, **151c**, **152b**, and **152c** of the driving semiconductor layer **151** and the switching semiconductor layer **152**. Here, the source electrodes **171b** and **172b** are connected with data lines crossing the gate lines in an insulated manner.

As described above, the capacitor includes the first capacitor plate **153** and the second capacitor plate **163**, and the gate insulating layer interposed between the two capacitor plates functions as a dielectric material. The first capacitor plate **153** is connected with the driving gate electrode **161**, and the second capacitor plate **163** is connected with common voltage line formed in parallel with the data line.

In the non-display area, the circuit unit **175** is formed on the interlayer insulating layer **170**. The circuit unit **175** is connected with the data line and the common voltage line and applies a voltage thereto. The circuit unit **175** is formed on the interlayer insulating layer **170** in the present exemplary embodiment, but the circuit unit **175** may be formed on the buffer layer **150** or the gate insulating layer **160** and may include at least one of the electrode materials forming the thin film transistor.

In the display area, a pixel defining layer **180** is formed on the interlayer insulating layer **170** and the source/drain electrodes **171** and **172**. A portion where the pixel defining layer **180** mostly becomes a non-light emission area is formed, and a pixel opening is formed in a portion corresponding to the pixel electrode **710** such that the portion becomes a light emission area, that is, a pixel area. The pixel defining layer **180** may be formed with resin such as polyacrylates-based resin and polyimides-based resin or may be formed with a silica-based inorganic material.

The organic emission layer **720** is formed on the pixel electrode **710**, the common electrode **730** is formed on the organic emission layer **720** and the pixel defining layer **180**, and the pixel electrode **710**, the organic emission layer **720**, and the common electrode **730** form the organic light emitting element **70**.

The organic emission layer **720** is formed with a low molecular weight organic material or a high molecular weight organic material, and may have a multiple layered structure with more than one of an emissive layer, a hole injection layer (HIL), a hole transporting layer (HTL), an electron transporting layer (ETL), and an electron injection layer (EIL).

As described above, in the present exemplary embodiment, the pixel electrode **710** is formed with a transparent conductive material and the common electrode **730** is formed with a metal having a high reflectivity, and thus the OLED display **100** according to the present exemplary embodiment is formed as a bottom emission type so that light emitted from the organic emission layer **720** is transmitted in a direction of the first substrate **110**. However, the present invention is not limited thereto, and the OLED display may be formed as a front emission type or a dual emission type by forming the common electrode as a transparent electrode.

Further, in the present exemplary embodiment, the pixel electrode **710** is formed as an anode, and the common electrode **730** is formed as a cathode, but the present invention is not limited thereto. That is, the pixel electrode and the common electrode may be formed as a cathode and an anode, respectively.

In the present exemplary embodiment, the inorganic protective layer **190** is formed on the common electrode **730** of the display area and the circuit unit **175** of the non-display area of the first substrate **110**. The inorganic protective layer **190** is formed to wholly cover the common electrode **730** and the circuit unit **175** so that the common electrode **730** and the

circuit unit **175** are not exposed to the outside. The inorganic protective layer **190** may be formed with silicon nitride or silicon oxide.

The sealing member **130** and the getter **140** are formed on the inorganic protective layer **190** of the non-display area of the first substrate **110**. The sealing member **130** may be formed at a location that at least partially overlaps the circuit unit **175**, and the sealing member **130** may be formed with epoxy or frit to seal the first substrate **110** and the second substrate **120**. In addition, the getter **140** is provided to reduce (or eliminate) moisture or oxygen, and may include a metal such as calcium, barium, magnesium, titanium, or a metal oxide, or a complex metal hydride.

The second substrate **120** is arranged on the sealing member **130** of the non-display area and the inorganic protective layer **190** of the display area.

As described, the OLED display **100** according to the present exemplary embodiment includes the inorganic protective layer **190** formed to cover the common electrode **730** of the organic light emitting element **70** and the circuit unit **175** of the non-display area so that the organic light emitting element **70** and the circuit unit **175** can be protected from the external environment. That is, when the second substrate **120** is sealed with the first substrate **110**, damage due to scratching of the common electrode **730** can be reduced (or suppressed), and when the sealing member **130** is formed on the circuit unit **175**, damage to the circuit unit **175** during a hardening process of a sealant can be reduced (or suppressed).

In addition, the sealing member **130** and the getter **140** can be formed on the circuit unit **175**, and the dead space of the OLED display **100** can be reduced so that the substrate can be more effectively used.

FIG. 3A to FIG. 3H sequentially show a manufacturing method of an OLED display according to an exemplary embodiment. Hereinafter, a manufacturing method of an OLED display **100** according to the present exemplary embodiment will be described.

Referring to FIG. 3A, a buffer layer **150** is formed on a first substrate **110**. The first substrate **110** is formed with an insulating material such as glass, quartz, or ceramic. The buffer layer **150** may be formed with silicon nitride, silicon oxide, or silicon oxynitride and may be deposited on the entire area of the first substrate **110**.

An amorphous silicon layer is formed on the buffer layer **150** and then crystallized such that a polycrystalline silicon layer is formed. Various known methods using heat, lasers, electrical fields, or catalyst metals may be used for the crystallization. After the polycrystalline silicon layer is formed, the layer is patterned through a photolithography process using a first pattern mask such that a driving semiconductor layer **151'**, a switching semiconductor layer **152'**, and a first capacitor plate **153'** are formed.

Referring to FIG. 3B, a gate insulating layer **160** is formed on the driving semiconductor layer **151'**, the switching semiconductor layer **152'**, and the first capacitor plate **153'**. The gate insulating layer **160** may be formed with silicon nitride or silicon oxide, and is formed to cover the buffer layer **150** and the polycrystalline silicon layer using a plasma chemical vapor deposition (CVD) method or the like.

After the gate insulating layer **160** is formed, a transparent conductive layer and a gate metal layer are sequentially formed on the gate insulating layer **160**. The transparent conductive layer and the metal layer are patterned through the photolithography process using a second pattern mask such that gate electrodes **161** and **162**, pixel electrodes **710** and **710'**, second capacitor plates **163** and **163'** and gate lines connected with the gate electrodes, pixel electrodes, and the

second capacitor plates are formed. In this case, the transparent conductive layer may include ITO or IZO, and the gate metal layer may include a low resistance metal such as aluminum, copper, silver, molybdenum, and the like.

Sequentially, impurities are injected into semiconductor layers **151** and **152** using the gate electrodes **161** and **162** as a mask to form source/drain areas **151b**, **151c**, **152b**, and **152c** which are doped with the impurities and channel areas **151a** and **152a** which are not doped with the impurities.

Referring to FIG. 3C, an interlayer insulating layer **170** is formed on the gate electrodes **161** and **162**. The interlayer insulating layer **170** may be formed with silicon nitride or silicon oxide, and is formed to cover the gate insulating layer **160** and the gate electrodes **161** and **162**.

Then, the interlayer insulating layer **170** is patterned through the photolithography process using a third pattern mask to expose the pixel electrodes **710** and **710'** and the second capacitor plates **163** and **163'**. In addition, contact holes CNT exposing the source/drain areas **151b**, **151c**, **152b**, and **152c** of the semiconductor layers **151** and **152** are formed through the interlayer insulating layer **170** and the gate insulating layer **160** by patterning the interlayer insulating layer **170**.

Referring to FIG. 3D, the transparent layer is exposed by etching the metal layers **710'** and **163'** of the pixel electrode **710** and the second capacitor plate **163**, respectively. Sequentially, a data metal layer is formed on the interlayer insulating layer **170** and then patterning is performed through the photolithography process using a fourth pattern mask such that the source/drain electrodes **171** and **172** and data lines and common voltage lines connected with the source electrodes are formed. The source/drain electrodes **171** and **172** are respectively connected with the source/drain areas **151b**, **151c**, **152b**, and **152c** of the semiconductor layer **151** and **152** through the contact holes CNT. A circuit unit **175** connected with the data line and the common voltage line may be formed on the non-display area of the first substrate **110**.

Referring to FIG. 3E, a pixel defining layer **180** is formed to cover the source/drain electrodes **171** and **172** on the interlayer insulating layer **170** in the display area of the first substrate **110**. The pixel defining layer **180** has an opening partially exposing the pixel electrode **710**. The opening is formed through the photolithography process using a fifth pattern mask. In this case, the opening corresponds to a light emission area, that is, a pixel area. The pixel defining layer **180** may be formed with polyacryl-based resin, polyamides-based resin, or silica-based inorganic material.

Referring to FIG. 3F, an organic emission layer **720** is formed on the pixel electrode **710**, and a common electrode **730** is formed to cover the organic emission layer **720** and the pixel defining layer **180** on a display area of the first substrate **110** such that an organic light emitting element **70** is formed. The organic emission layer **720** may include at least one of a hole injection layer (HIL), a hole transport layer (HTL), an electron transport layer (ETL), and an electron injection layer (EIL). In the present exemplary embodiment, for realization of a bottom-emission structure, a material having high reflectivity and low resistivity such as magnesium, silver, aluminum, chromium, and an alloy thereof may be used to form the common electrode **730**. Accordingly, light emitted from the organic emission layer **720** is reflected by the common electrode **730** and emitted through the pixel electrode **710** and the first substrate **110** to the outside such that an image can be displayed.

Referring to FIG. 3G, the inorganic protective layer **190** is formed on the first substrate **110**. The inorganic protective layer **190** may be formed with silicon nitride or silicon oxide,

and wholly covers the display area and the non-display area of the first substrate. Thus, the inorganic protective layer 190 covers the common electrode 730 of the display area and the circuit unit 175 of the non-display area such that the common electrode 730 and the circuit unit 175 are not exposed to the outside.

Referring to FIG. 3H, a sealant is applied to (or coated on) the inorganic protective layer 190 of the display area in the first substrate 110. The sealant may be coated on a location at least partially overlapping the circuit unit 175 for more effective use of the substrate by reducing the dead space. Epoxy or frit may be used as the sealant, but the present invention is not limited thereto. After applying (or coating) the sealant, the second substrate 120 is arranged to be opposite to the first substrate 110 and the sealant is hardened such that the sealing member 130 is formed. The sealant may be hardened by irradiating ultraviolet (UV) light, and the first substrate 110 and the second substrate 120 are sealed to each other as the sealant is hardened.

During the sealant hardening process for sealing the first substrate 110 and the second substrate 120, the ultraviolet (UV) light is irradiated, and the circuit unit 175 of the non-display area may be exposed during the sealant hardening process so that the circuit unit 175 may be damaged.

However, in the present exemplary embodiment, the circuit unit 175 is covered by the inorganic protective layer 190 and thus ultraviolet (UV) light is not directly irradiated to the circuit unit 175 during the sealant hardening process so that the circuit unit 175 can be protected. Accordingly, the sealing member 130 can be formed by applying (or coating) the sealant on the circuit unit 175, thereby reducing the dead space. In addition, since the circuit unit 175 is not exposed to the outside and is protected by the inorganic protective layer 190, corrosion of the circuit unit 175 due to moisture can be prevented. Further, since the sealing member 130 is formed on the inorganic protective layer 190, the adhesiveness can be improved.

In the present exemplary embodiment, the inorganic protective layer 190 covers the common electrode 730 of the display area so that the common electrode 730 can be prevented from being scratched when the second substrate 120 is adhered to the first substrate 110, thereby protecting the organic light emitting element 70.

As described, according to the manufacturing method of the OLED display of the present exemplary embodiment, the OLED display 100 can be formed using only five masks, and the dead space can be reduced while protecting the organic light emitting element 70 and the circuit unit 175 so that the substrate can be more efficiently used.

In the present exemplary embodiment, a getter 140 may be further formed at an inner side of the sealing member 130. The getter 140 is provided to reduce (or eliminate) moisture or oxygen in the OLED display, and may include a metal such as calcium, barium, magnesium, titan, a metal oxide, or complex metal hydride. The getter 140 may also be formed on the circuit unit 175 covered by the inorganic protective layer 190 so that moisture or oxygen can be reduced (or eliminated) without increasing the dead space in the non-display area, thereby extending the life-span of the organic light emitting element 70.

While this disclosure has been described in connection with what is presently considered to be practical exemplary embodiments, it is to be understood that the invention is not limited to the disclosed embodiments, but, on the contrary, is intended to cover various modifications and equivalent arrangements included within the spirit and scope of the appended claims and equivalents thereof.

Description of Some of the Reference Numerals

100: organic light emitting diode (OLED) display	70: organic light emitting element
50: driving element	120: second substrate
110: first substrate	140: getter
130: sealing member	151: driving semiconductor layer
150: buffer layer	153: first capacitor plate
152: switching semiconductor layer	161: driving gate electrode
160: gate insulating layer	163: second capacitor plate
162: switching gate electrode	171a: driving drain electrode
170: interlayer insulating layer	172a: switching drain electrode
171b: driving source electrode	175: circuit unit
172b: switching source electrode	190: inorganic protective layer
180: pixel defining layer	720: organic emission layer
710: pixel electrode	CNT: contact holes
730: common electrode	

What is claimed is:

1. An organic light emitting diode (OLED) display comprising:
 - a first substrate comprising a display area and a non-display area;
 - a driving element on the display area of the first substrate;
 - a circuit unit on the non-display area of the first substrate;
 - an organic light emitting element on the driving element, and comprising a pixel electrode, an organic emission layer, and a common electrode; and
 - an inorganic protective layer covering the circuit unit and the common electrode of the organic light emitting element.
2. The OLED display of claim 1, further comprising a sealing member on the inorganic protective layer in the non-display area of the first substrate and a second substrate on the sealing member.
3. The OLED display of claim 2, further comprising a getter on the inorganic protective layer in the non-display area of the first substrate, the getter being closer to the display area than the sealing member is.
4. The OLED display of claim 2, wherein the sealing member is at a location at least partially overlapping the circuit unit.
5. The OLED display of claim 4, further comprising a getter on the inorganic protective layer in the non-display area of the first substrate, the getter being closer to the display area than the sealing member is.
6. The OLED display of claim 2, wherein the inorganic protective layer comprises silicon nitride (SiNx) or silicon oxide (SiOx).
7. The OLED display of claim 6, further comprising a getter on the inorganic protective layer in the non-display area of the first substrate, the getter being closer to the display area than the sealing member is.
8. The OLED display of claim 2, wherein the sealing member comprises epoxy or frit.
9. The OLED display of claim 8, further comprising a getter on the inorganic protective layer in the non-display area of the first substrate, the getter being closer to the display area than the sealing member is.
10. The OLED display of claim 2, wherein the first substrate and the second substrate are formed of glass.
11. The OLED display of claim 10, further comprising a getter on the inorganic protective layer in the non-display area of the first substrate, the getter being closer to the display area than the sealing member is.
12. A method for manufacturing an organic light emitting diode (OLED) display, the method comprising:

11

forming a driving element and a circuit unit in a display area and a non-display area of a first substrate, respectively;

forming an organic light emitting element, comprising a pixel electrode, an organic emission layer, and a common electrode, on the driving element; and

forming an inorganic protective layer to cover the circuit unit and the common electrode of the organic light emitting element.

13. The method of claim 12, further comprising: applying a sealant to the inorganic protective layer in the non-display area of the first substrate;

disposing a second substrate on the sealant; and adhering the first substrate and the second substrate to each other by hardening the sealant.

14. The method of claim 13, further comprising forming a getter on the inorganic protective layer at a location in the non-display area of the first substrate, the getter being closer to the display area than the sealant is.

15. The method of claim 13, wherein the sealant is applied to a location at least partially overlapping the circuit unit.

16. The method of claim 15, further comprising forming a getter on the inorganic protective layer at a location in the non-display area of the first substrate, the getter being closer to the display area than the sealant is.

12

17. The method of claim 13, wherein the inorganic protective layer comprises silicon nitride (SiNx) or silicon oxide (SiOx).

18. The method of claim 17, further comprising forming a getter on the inorganic protective layer at a location in the non-display area of the first substrate, the getter being closer to the display area than the sealant is.

19. The method of claim 13, wherein the sealant comprises epoxy or frit.

20. The method of claim 19, further comprising forming a getter on the inorganic protective layer at a location in the non-display area of the first substrate, the getter being closer to the display area than the sealant is.

21. The method of claim 13, wherein the first substrate and the second substrate are formed of glass.

22. The method of claim 21, further comprising forming a getter on the inorganic protective layer at a location in the non-display area of the first substrate, the getter being closer to the display area than the sealant is.

23. The method of claim 13, wherein the sealant is hardened by irradiating ultraviolet (UV) light thereto.

24. The method of claim 23, further comprising forming a getter on the inorganic protective layer at a location in the non-display area of the first substrate, the getter being closer to the display area than the sealant is.

* * * * *

专利名称(译)	有机发光二极管显示器及其制造方法		
公开(公告)号	US9312316	公开(公告)日	2016-04-12
申请号	US14/165331	申请日	2014-01-27
[标]申请(专利权)人(译)	三星显示有限公司		
申请(专利权)人(译)	三星DISPLAY CO. , LTD.		
当前申请(专利权)人(译)	三星DISPLAY CO. , LTD.		
[标]发明人	YOU CHUN GI CHOI JOON HOO		
发明人	YOU, CHUN-GI CHOI, JOON-HOO		
IPC分类号	H01L51/52 H01L51/54 H01L27/32 H01L51/56		
CPC分类号	H01L27/3244 H01L51/5246 H01L51/56 H01L51/5259 H01L51/5253		
优先权	1020100139428 2010-12-30 KR		
其他公开文献	US20140138668A1		
外部链接	Espacenet	USPTO	

摘要(译)

一种有机发光二极管(OLED)显示器,包括:第一基板,包括显示区域和非显示区域;第一基板的显示区域上的驱动元件,包括驱动薄膜晶体管,开关薄膜晶体管和电容器;第一基板的非显示区域上的电路单元;驱动元件上的有机发光元件,包括像素电极,有机发光层和公共电极;覆盖电路单元和有机发光二极管的公共电极的无机保护层;第一基板的非显示区域中的无机保护层上的密封构件;密封件上的第二基板。

